

---

# *QUADRANT AND BI-CELL*

## **SILICON PHOTODIODE AMPLIFIER MODULE**



Quadrant and bi-cell photodiodes act on the principle of having two or four separate photodiode elements (active areas) separated by a small gap on a common substrate with a shared cathode. The anode or active area of each element is individually available so that a light spot illuminating a single quadrant can be electrically characterized as being in that quadrant only. As this spot is translated across the detector, its energy is distributed between adjacent elements, and the difference in electrical contribution to each segment defines its relative position with respect to the center of the device. The relative intensity profile over the active area of the device then determines light spot position.

Two important observations should be made regarding this transfer function. First, the detector will provide position information only over a linear distance of twice the spot diameter or until the edge of the spot has reached the detector gap. Thereafter the spot location can only be identified as which particular element it resides on, but not exactly where in that element. Thus when working with lasers or collimated sources, the image may require defocusing to obtain the maximum range. Second, the transfer function for a circular spot is not linear, mainly because its linear movement is not proportional to the percentage of its area which shifts between adjacent segments. Hence, a line of quadrangle of light would provide best linearity. In all these cases, it is presumed the spot intensity distribution is symmetrical.

These limitations illustrates that segmented photodiodes are most effective when used for nulling and centering rather than a linear position indicators. OSI Optoelectronics "Later-Effect" position sensors provide a better solution for this purpose. For centering applications, however, the performance of segmented photodiodes is unparalleled and resolutions of 0.1  $\mu\text{m}$  or better may be obtained. This is due to the excellent response uniformity from element to element and sensitivity (due to low noise current). These devices are available in a wide variety of active area sizes and gaps. Please refer to our Optoelectronics catalog for additional information and specifications.

For obtaining the position information, the signal outputs shall be measured for each quadrant, appropriately subtracted, summed and divided. OSI Optoelectronics' QDXX-0-SD series offer a combined quadrant silicon photodiode with the first stage where electronics are operated in transimpedance mode to increase the photocurrent as well as conversion to a voltage and the second stage performs the sum and difference functions of various quadrant signals. The two difference signals are voltage analogs of the relative intensity difference of the light sensed by opposing pairs of the photodiode quadrant elements. In addition, the amplified sum of all four quadrant element is provided as the sum signal. (The QDXX-0-SD module is available with QD50-0 quadrant photodiode or the smaller QD7-0 as well as our SPOT series quadrants and bi-cells).

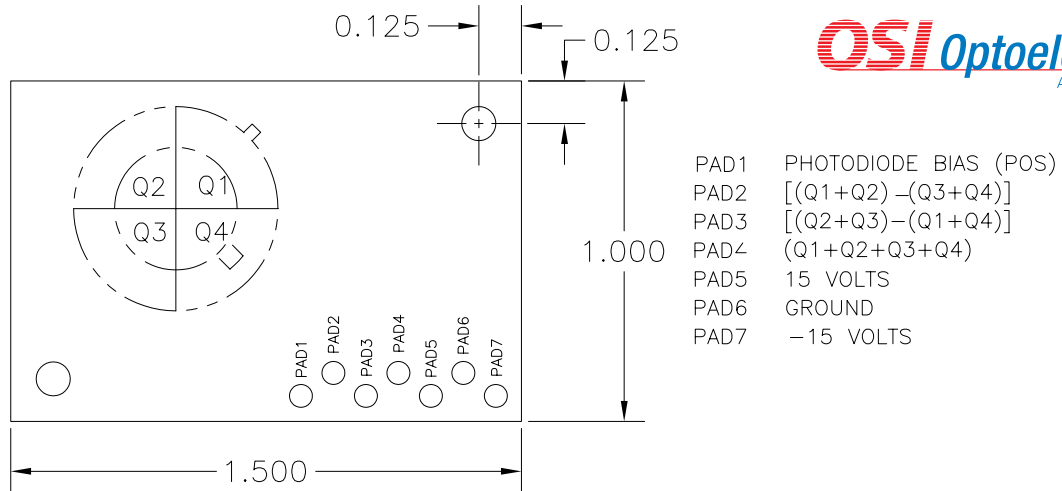

The outputs of the QDXX-0-SD are T-B ('Top' minus 'Bottom'), L-R ('Left' minus 'Right') and SUM and they are governed by the following formulas:

$$V_{T-B} = -[(i_1 + i_2) - (i_3 + i_4)] \times 10^4$$

$$V_{L-R} = -[(i_2 + i_3) - (i_1 + i_4)] \times 10^4$$

$$V_{SUM} = -(i_1 + i_2 + i_3 + i_4) \times 10^4$$

Where  $i_x$  is the current output generated by the photodiode element in quadrant  $Q_x$  when that quadrant is illuminated and  $10^4$  is the gain in the first transimpedance stage.

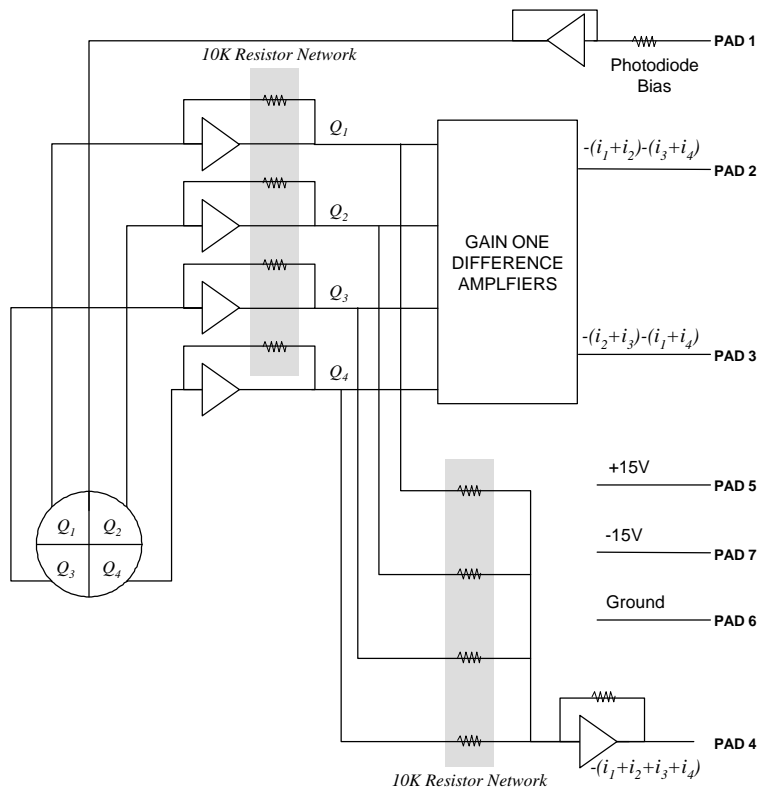

A 10 x n/D divider is often used to divide the sum signals into the difference. This ratio cancels out the effects of varying source intensity which might otherwise be deemed as an apparent shift in the spot position. If the source were known to be very stable, it would suffice to measure the difference signals alone.

Arithmetically, the X and Y positions of the spot are characterized by:

$$X = \frac{(i_1 + i_3) - (i_2 + i_4)}{i_1 + i_2 + i_3 + i_4}$$
$$Y = \frac{(i_1 + i_2) - (i_3 + i_4)}{i_1 + i_2 + i_3 + i_4}$$

#### BEAM SIZE

A spot size smaller than the photodiode diameter is recommended for optimum performance. The light spot may be generated either by direct or reflected beam from a focused light source and smaller than the total diameter of the quadrant. In general, smaller spot diameters produce greater voltage differentials for equal position changes of the light post.

The separation of distance between the elements (gap), determines the minim spot size that can be used. As the light spot size approaches the gap size, the sensitivity of the difference output is reduced. The range of the off axis deviation of the beam is limited to the difference of the photodiodes quadrant radius and the light spot radius.

#### BEAM SYMMETRY

If the beam spot is not symmetrical in the T to B and L to R axes, the T-B and L-R outputs may exhibit slight non-linearity when related to movement or rotation of the light source. This consideration is generally more important in open loop measurement applications but can safely be ignored in most closed loop positioning applications.

#### PHOTODIODE BIAS

The photodiode can be operated either in photovoltaic (no bias) or reverse bias mode. The PDBIAS line is connected via a resistor divider to the non-inverting input of a voltage follower operational amplifier. The PDBIAS line may be left un-terminated, grounded or connected to a voltage source of zero volts to operate in photovoltaic mode. If the PDBIAS line is connected to a positive voltage source (but less than  $V_{CC}$ ) the photodiodes elements will be biased at  $0.91 \times V_B$ .

**CAUTION: Negative voltages applied to the PDBIAS line will render the QDXX-0-0SD INOPERATIVE.**

#### USING THE SUM OUTPUT

In some applications the sum output may be used to accomplish two objectives.

First, the sum signal may be used for initial alignment of the beam on the photodiode quadrant. The T-B and L-R signals may then be used to position the beam directly in the center of the array. This may be accomplished by the following procedure:

1. Adjust the beam until the sum output is maximum.
2. Adjust the beam until the T-B output is minimum.

3. Adjust the beam until the L-R output is minimum.

In general the optimum alignment is achieved when the T-B and L-R signals are zero and the sum signal is near local maximum.

Second, the sum signal may also be used to normalize the T-B and L-R signals. In this case the normalization of the T-B and L-R signals is effective in reducing intensity fluctuations in the light source. This approach is helpful in open loop measurement applications.