

SD041-11-21-214

0.84mm² Biconvex Lens Silicon Photodiode

The SD041-11-21-214 utilizes a biconvex lens to focus light on to a 1.0x0.84mm active area silicon photodiode in a TO-46 package. The device provides a largely increased sensitivity to ambient light and fast response time within the broad spectral range extending from 350nm to 1100nm. The increased sensitivity is due to the focusing effects of the biconvex lens.

Applications

Low Light Conditions

Medical

Industrial Switching

Military

Features

Biconvex Focusing Lens

Improved Sensitivity

0.85mm² Active Area

Absolute Maximum Ratings

Parameter	Symbol	Min	Max	Unit
Reverse Voltage	V_R	-	50	V
Operating Temperature	T_{OP}	-40	+100	°C
Storage Temperature	T_{STG}	-55	+125	°C

Package

TO-46

Typical Electro-Optical Specifications at $T_A=23\text{ °C}$

Parameter	Test Conditions	Symbol	Min	Typ	Max	Unit
Active Area	-	A.A.	-	0.85	-	mm ²
Spectral Range	Spot Scan	$\Delta\lambda$	350	-	1100	nm
Short Circuit Current	H=1000Lux	I_{SC}	-	30	-	μA
Capacitance	$V_R=0V$, F=1MHz	C_J	-	17.5	-	pF
Dark Current	$V_R=50V$	I_D	-	0.1	10	nA
Shunt Resistance	$V_R=10mV$	R_{sh}	500	-	-	MΩ

Spot Distribution

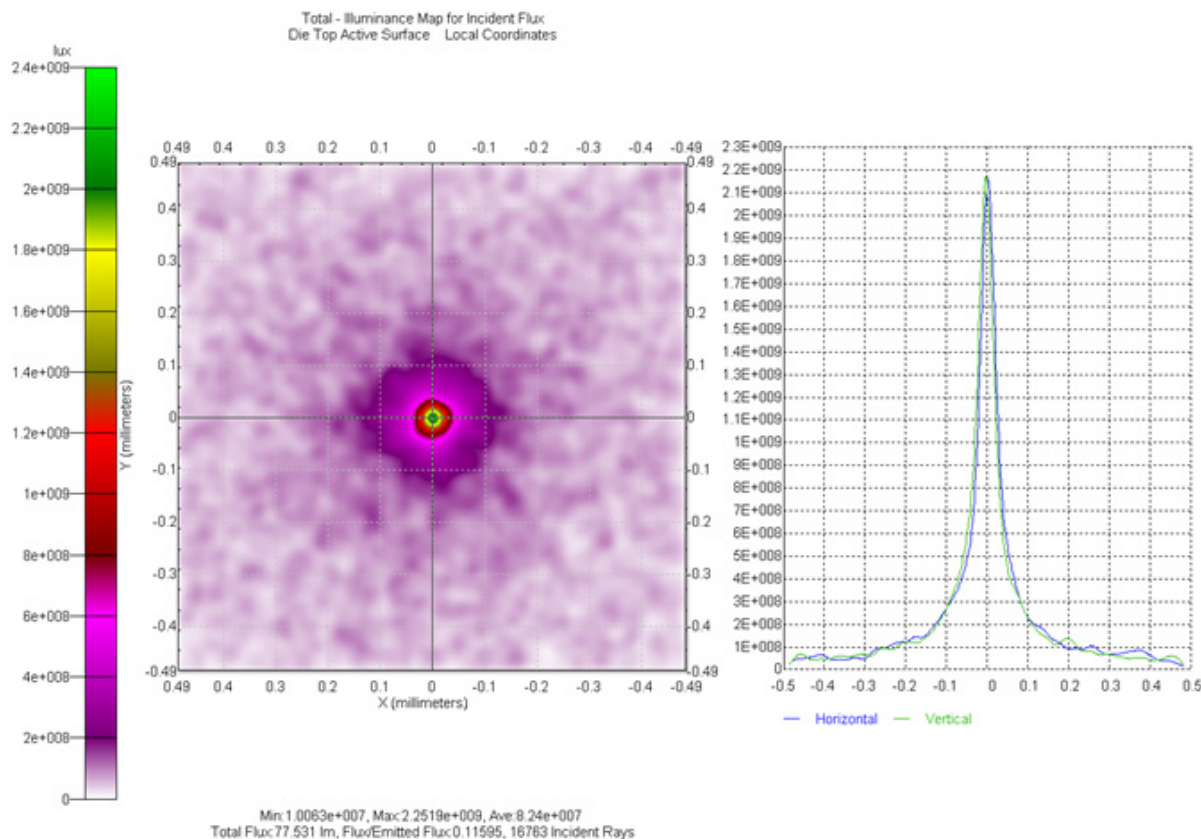

Typical Spectral Response

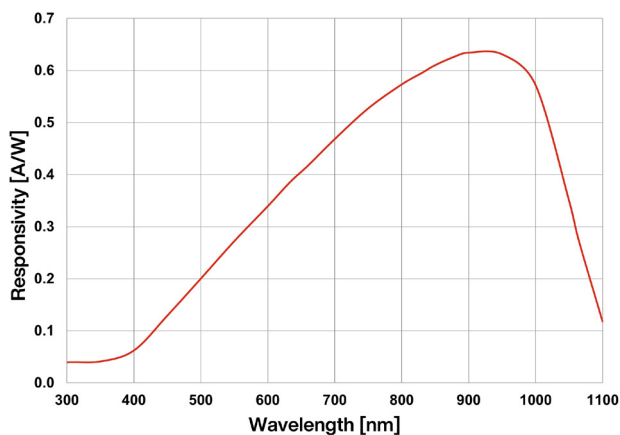

Mechanical Specifications

Units are in inches [mm]

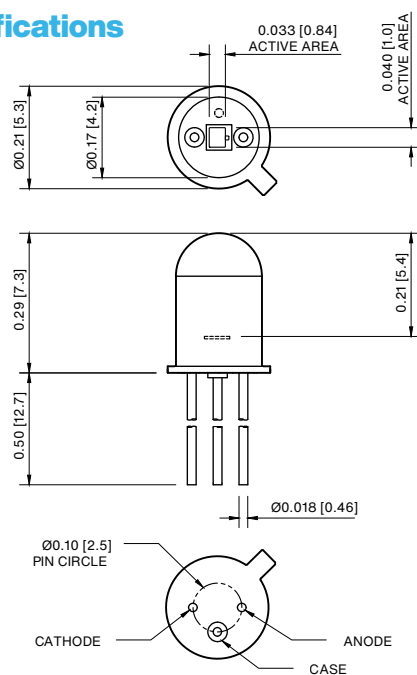

General Care and Handling Instructions

Photodiodes:

Handling and Storage

- Handle Photodiodes gently to prevent damage.
- Avoid exposing Photodiodes to temperatures exceeding the storage temperature rating of the device.
- Maintain a non-condensing environment for optimum performance and lifetime.

Cleaning

- Gently clean the glass (borosilicate or quartz window) using a 50/50 mixture of Methanol and isopropyl alcohol and a soft, optical-grade pad.

Special Considerations for Plastic or Epoxy Encapsulated Photodiodes

- Protect from intense light sources such as direct sunlight.
- Avoid exposure to harsh chemicals like THINNERS, ACETONE, and TRICHLOROETHYLENE.
- Cleaning with a 50/50 mixture of Methanol and isopropyl alcohol (IPA) is recommended. Cleaning in an ultrasonic bath is generally not recommended.

CdS Photocells:

Handling and Storage

- Handle CdS Photocells gently to prevent damage.
- Avoid exposing CdS Photocells to temperatures exceeding the storage temperature rating of the device.
- Maintain a non-condensing environment for optimum performance and lifetime.

Cleaning

- Gently clean the glass or plastic covering using a 50/50 mixture of Methanol and isopropyl alcohol and a soft, optical-grade pad.

Special Considerations

- DO NOT use Vapor Phase Soldering or Reflow Soldering for CdS components.

Optocouplers and LEDs:

Handling and Storage

- Handle Optocouplers and LEDs gently to prevent damage.
- Avoid exposing the devices to temperatures exceeding the storage temperature rating of the device.
- Maintain a non-condensing environment for optimum performance and lifetime.

Cleaning

- For plastic molded devices, cleaning with a 50/50 mixture of Methanol and isopropyl alcohol is recommended. Cleaning in an ultrasonic bath is generally not recommended.

Special Considerations

- Avoid exposing plastic molded devices or epoxy glob top devices to harsh chemicals like THINNERS, ACETONE, and TRICHLOROETHYLENE.

Electrostatic Discharge (ESD) Sensitivity:

- All devices are considered ESD-sensitive. They are shipped in ESD protective packaging. When unpacking and using these products, anti-ESD precautions should be observed.

Lead Trimming and Bending:

- Standard lead trimming after soldering is an acceptable practice; however, do not attempt to bend or modify the leads incorrectly, as it can damage the glass feed-through or the plastic encapsulant.

Soldering Instructions:

- Use a soldering iron with a tip temperature of 300°C max.
- Consult with your preferred solder manufacturer to determine a solder alloy and flux combination, as well as the reflow profile appropriate for your application.

General Precautions for all Devices

1. Moisture Prevention:

Ensure devices are stored in a dry environment to prevent moisture ingress, which can cause damage during soldering. Refer to J-STD-20 for guidance on proper baking procedures to prevent moisture related damage.

2. Lead Splaying:

If required, carefully splay the leads of the devices according to the specific application needs. Be cautious when splaying leads, as improper techniques may damage the device. Consult technical support or device datasheets for guidance on lead splaying.

3. Mechanical Stress:

Handle devices with care throughout the installation process to prevent damage.

4. Circuit Protection and Layout:

Optimize the circuit design and layout to ensure proper functioning and prevent damage to the devices. Include appropriate protection measures like ESD protection diodes, current-limiting resistors, and voltage regulation.

5. After-Sale Support:

For troubleshooting and device-specific inquiries, please consult with our technical support team. They can offer valuable guidance and suggestions on handling, operation, and application-related questions. To reach them, please contact the Advanced Photonix Applications group at Techsupport@advancedphotonix.com.

Legal Disclaimer

Information in this data sheet is believed to be correct and reliable. However, no responsibility is assumed for possible inaccuracies or omission. Specifications are subject to change without notice.

